

Tactical

TC230E

MAXIWAT RANGE OF THYRISTOR SWITCHING UNITS

INSTRUCTION MANUAL

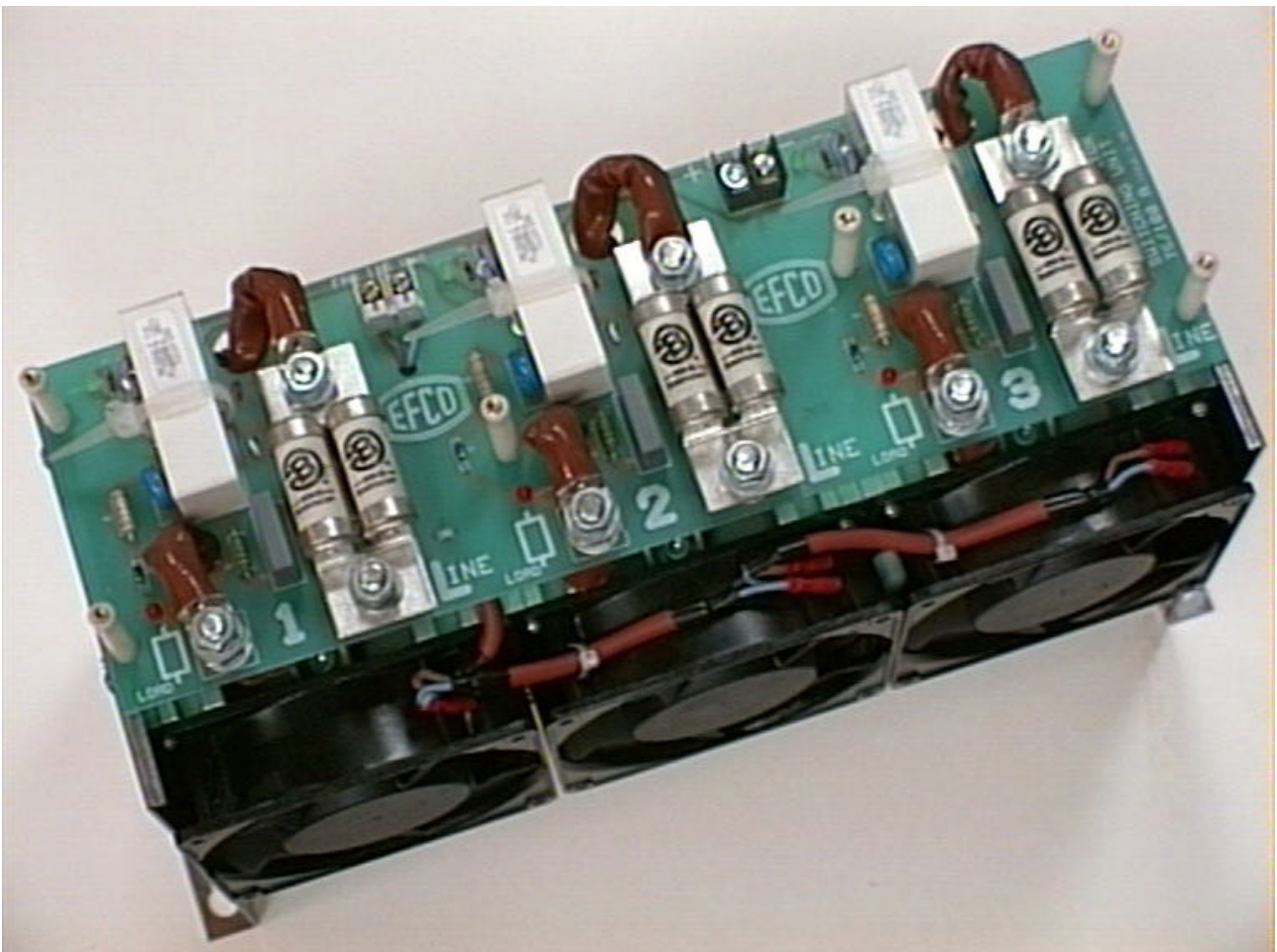

CONTENTS

DESCRIPTION	2	SPECIFICATION	7
EMC COMPLIANCE	2	ORDERING INFORMATION	7
INSTALLATION	3	DIMENSIONS	8
DIAGNOSTIC AID - LEDs	6	SUPPLIER INFORMATION	8

DESCRIPTION

The MAXIWAT TC230E range of thyristor switching units, combine high power capability with compact dimensions. With the emphasis on safety and reliability, the units are ruggedly housed.

They incorporate zero-voltage switching modules which are fully encapsulated for durability; the units accept d.c. drive signals from any suitable temperature or power controller.

Rated for up to 125A/440V per phase, the TC230E

family comprises assemblies with line current capacities of 40A, 55A, 75A, 100A and 125A. Each assembly is fully isolated and incorporates high speed fuse, excess voltage protection and an over temperature thermal cutout.

A standard feature of MAXIWAT TC230E units is the clear visual indication, by two LEDs, of input logic signal and fuse/load/thyristor integrity. The combination of the states of these two LEDs aids system fault finding.

EMC COMPLIANCE

Emission

The TC230E complies with the requirement of BS EN 50081-2: 1994, the European Generic emission standard, for industrial environment - provided a TC003 filter is connected to the three phase incoming supply lines.

Further information, see EMC Filter TC003 data sheet.

Immunity

The TC230E complies with the requirement of BS EN 50082-2: 1995, the European Generic immunity standard, for industrial environment.

INSTALLATION

Under normal operating conditions it is important that the TC230E power switching unit should be mounted VERTICALLY (as shown in figure 1 and 2), with the FAN end facing DOWNWARDS. Also the ambient temperature should not exceed 50°C.

If the TC230E cannot be mounted vertically or if the ambient temperature is higher than 50°C, please contact your supplier or Tactical Controls directly to determine suitability and possible operating constraints.

PROTECTION FUSE

The integral fuse in a MAXIWAT thyristor unit is designed primarily to protect the thyristors from any excessive over current condition. In the event of a fuse blowing, the replacement must be a high speed H.R.C. fuse of an approved type. Replacement fuses can be ordered directly from Tactical Controls or an equivalent type can be used. Fuse types for different current ratings are given in Table 1.

WIRING

There are four basic load configurations to the three-phase zero-voltage thyristor switching units; and these are:-

Figure 1b. 3-phase, star connected load.

Figure 1c. 3-phase, 3-wire, closed delta connected load.

Figure 2b. 3-phase, 4-wire, star connected load.

Figure 2c. 3-phase, open-delta connected load.

The basic wiring is as follow: the (LINE) terminal must be connected to the load supply L1, L2 or L3. One end of the load must be connected to the (LOAD) terminal LOAD1, LOAD2 or LOAD3. The loads can be connected in star or delta as shown in figure 1 and 2.

When connecting the LINE and LOAD to the TC230E, it is important to have the user connection and internal connection right next to each other so that the two crimps make direct contact. This is to minimise contact resistance.

The input logic signal supply must be connected to the terminals marked with 'I/P+' and 'I/P-', and these can be connected in parallel. The recommended minimum input cable size is 0.5mm square.

Table 1. Fuses and fuse ratings for the TC230E MAXIWAT range.

Current Rating (Arms)	Voltage Rating (Vrms)	Tactical Part no.	Equivalent Type
40A	240V	FUS-50LET	BRUSH-50LET
	440V	FUS-45ET	BRUSH-45ET
55A	240V	FUS-63LET	BRUSH-63LET
	440V	FUS-80ET	BRUSH-80ET
75A	240V	FUS-80LET	BRUSH-80LET
	440V	FUS-90EET	BRUSH-90EET
100A	240V	FUS-140EET	BRUSH-140EET
	440V	FUS-140EET	BRUSH-140EET
125A	240V	FUS-160EET	BRUSH-160EET
	440V	FUS-160EET	BRUSH-160EET

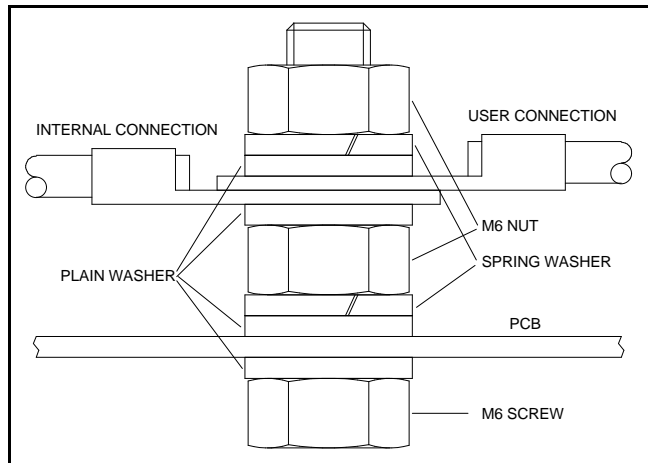

User connection for LOAD and LINE.

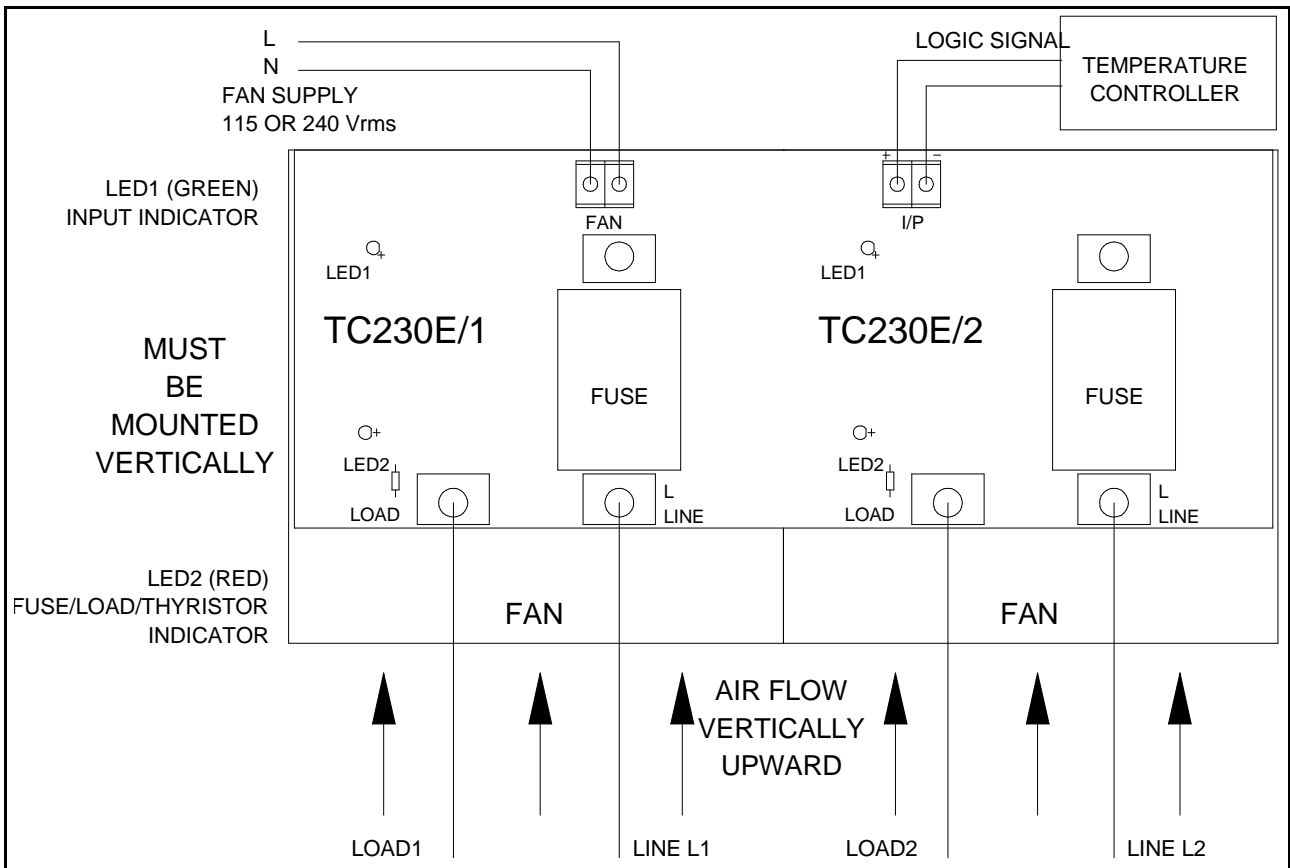

Figure 1a. 3-phase 3-wire star or closed delta wiring.

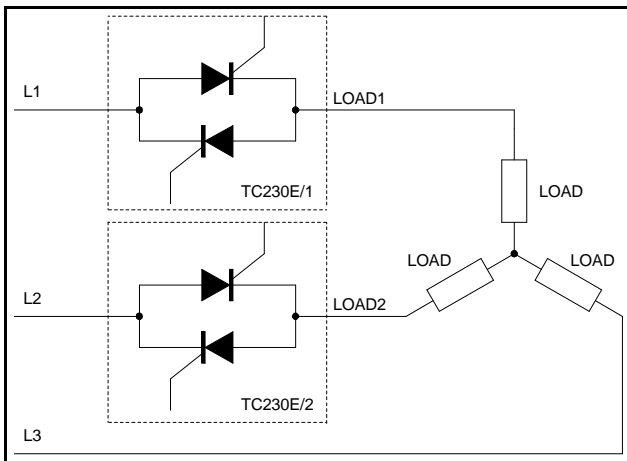

Figure 1b. 3-phase, 3-wire, star connected load.

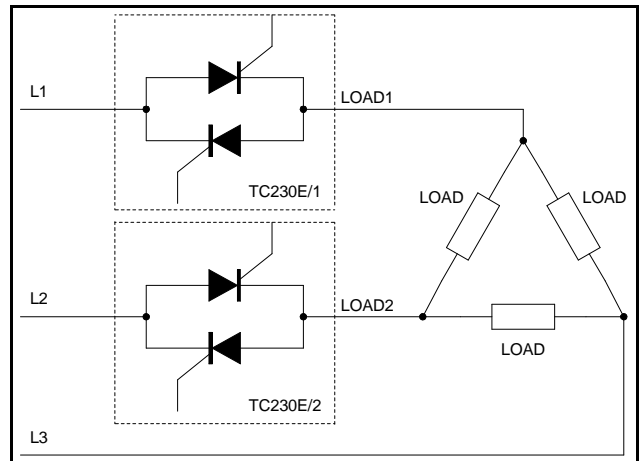

Figure 1c. 3-phase, 3-wire, closed delta connected load.

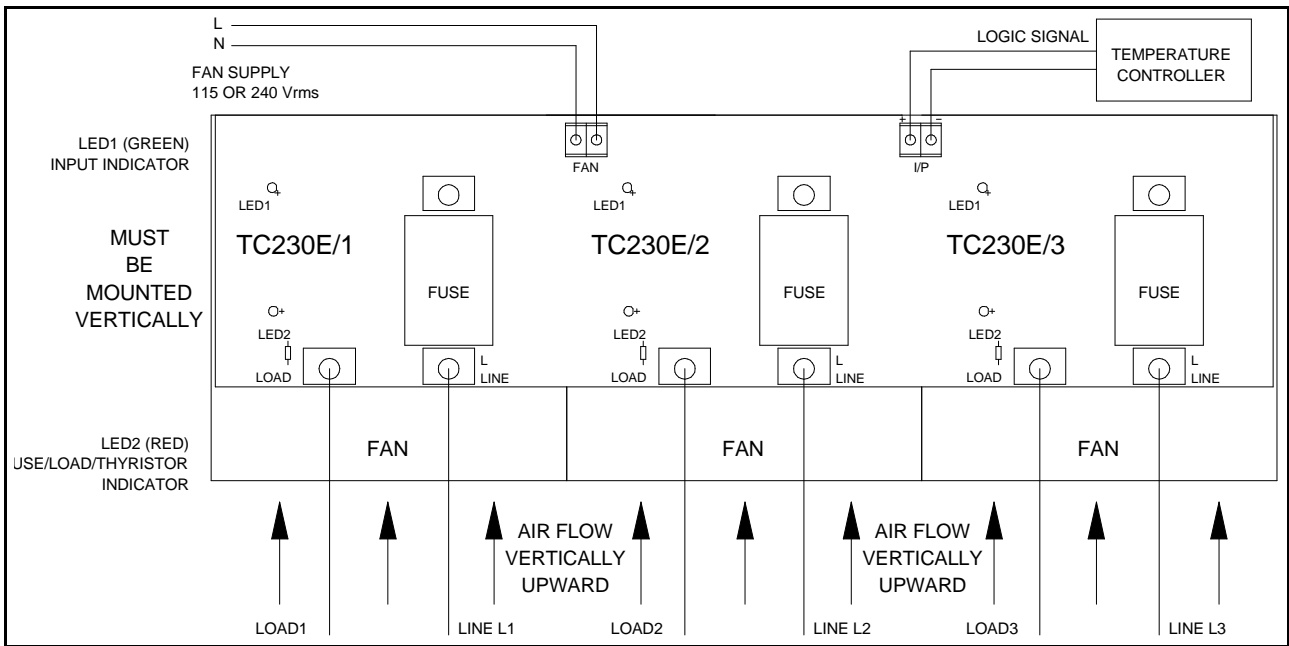

Figure 2a. 3-phase 4-wire star or 3-wire open delta wiring.

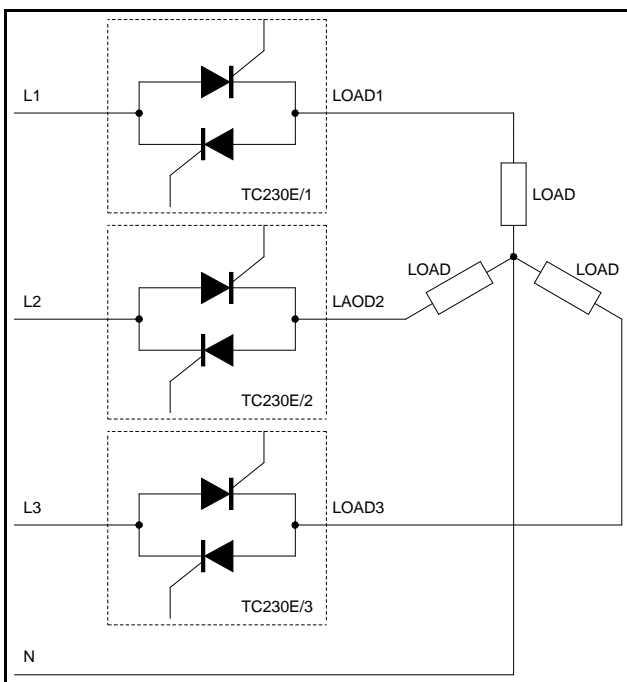

Figure 2b. 3-phase, 4-wire, star connected load.

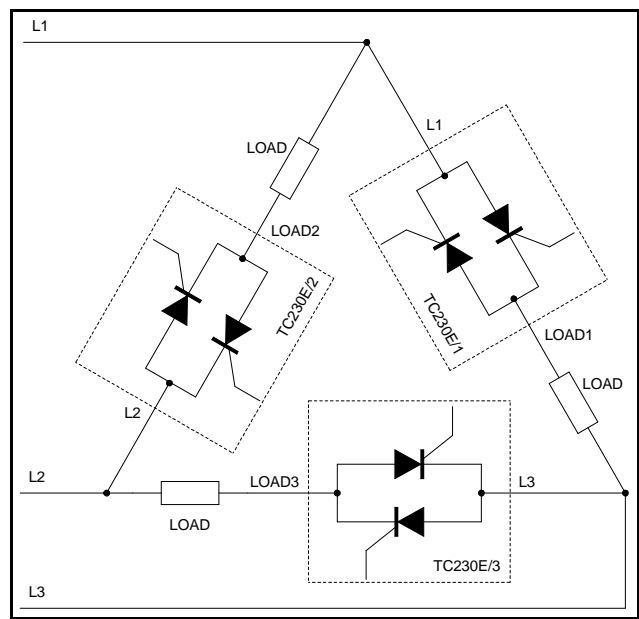

Figure 2c. 3-phase, 3-wire, open delta connected load.

DIAGNOSTIC AID - LEDs

The light emitting diode, LED 1 (green) near to the input terminals is used to indicate the input status. When the input is 0V, LED 1 is 'OFF' and when the input is greater than 5Vdc, LED 1 is 'ON'.

Illumination of the light emitting diode LED 2 (red) indicates that neither the fuse, nor load are open circuit. When the input signal is 0V, LED 2 should be 'ON'. When the input is high (5 to 30 Vdc), LED 2 is 'OFF'. Under normal operation, at any instant either LED 1 or LED 2 is 'ON'.

Combinations of the states of LEDs 1 and 2, together with the state of the input logic signal, which switches between 'HIGH' and 'LOW', provide a valuable diagnostic aid to fault finding; a summary of conditions and effects is given in Table 2.

A block diagram showing the diagnostic LEDs 1 and 2, is given in figure 3.

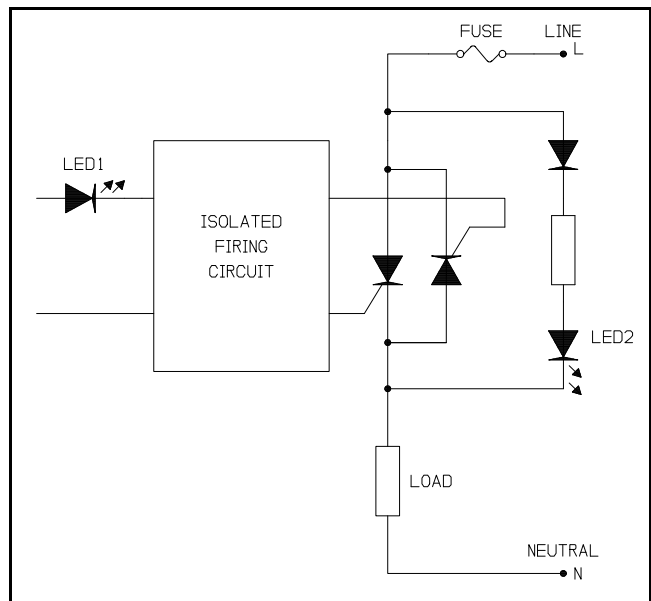

Figure 3. LED1 and LED2 diagnostic aids.

Note 1

With the load supply 'ON', the possible faults are:

- a) fuse-blown or
- b) open-circuited load or
- c) short-circuited thyristor (power to load permanently 'ON').

Note 2

Thyristor fails to switch on indicated by LED 2 permanently 'ON'. The possible faults are:

- a) insufficient input logic drive signal (must be greater than 5Vdc) or
- b) faulty open-circuited thyristor or
- c) faulty drive circuitry

Note 3

Check for reversal of input signal leads.

Table 2. Use of LEDs 1 and 2 - a diagnostic aid.

INPUT/LED STATE COMBINATIONS			
INPUT	LED1 (green)	LED2 (red)	CONDITION
HIGH	on	off	normal and with
LOW	off	on	load supply on
HIGH	on	off	normal and with
LOW	off	off	load supply off
HIGH	on	off	faulty but
LOW	off	off	see Note 1
HIGH	on	on	faulty but
LOW	off	on	see Note 2
HIGH	off	on	faulty but
LOW	off	on	see Note 3

TECHNICAL SPECIFICATION

INPUT

Logic
 Must operate at
 Must release at
 Constant current

5 - 30 Vdc
 >4.5 Vdc
 <1.5 Vdc
 12 mA typical

Current rating 40 to 125 A.
 Input/Output isolation 2500 Vrms.
 Supply frequency 40 to 70 Hz.

ENVIRONMENT

Ambient operating temp. 0 to 50 °C
 Storage temperature -20 to 70°C

OUTPUT

Supply voltage 100 to 440 Vrms
 (+10 -15%)

ORDERING INFORMATION

The TC230E range can be ordered by description or by the following code.

230E - - - - -00

INPUT.....: : : :
 CURRENT RATING.....: : : :
 VOLTAGE RATING.....: : : :
 FAN VOLTAGE.....: : : :
 LOAD CONFIGURATION.....: : : :

INPUT

Logic
 5-30 Vdc 1

CURRENT RATING

40 A 40
 55 A 55
 75 A 75
 100 A 100
 125 A 125

VOLTAGE RATING

240 V 240
 440 V 440

FAN VOLTAGE

110 Vrms 110
 240 Vrms 240

LOAD CONFIGURATION

4 wire, star (figure 3) 1
 3 wire, closed-delta or star
 (figure 1 and 2) 2
 3 wire, open-delta (figure 4) 3

End of code 00

For applications other than constant resistive loads, or any other currents and voltage ratings, not listed above, please contact our sales office.

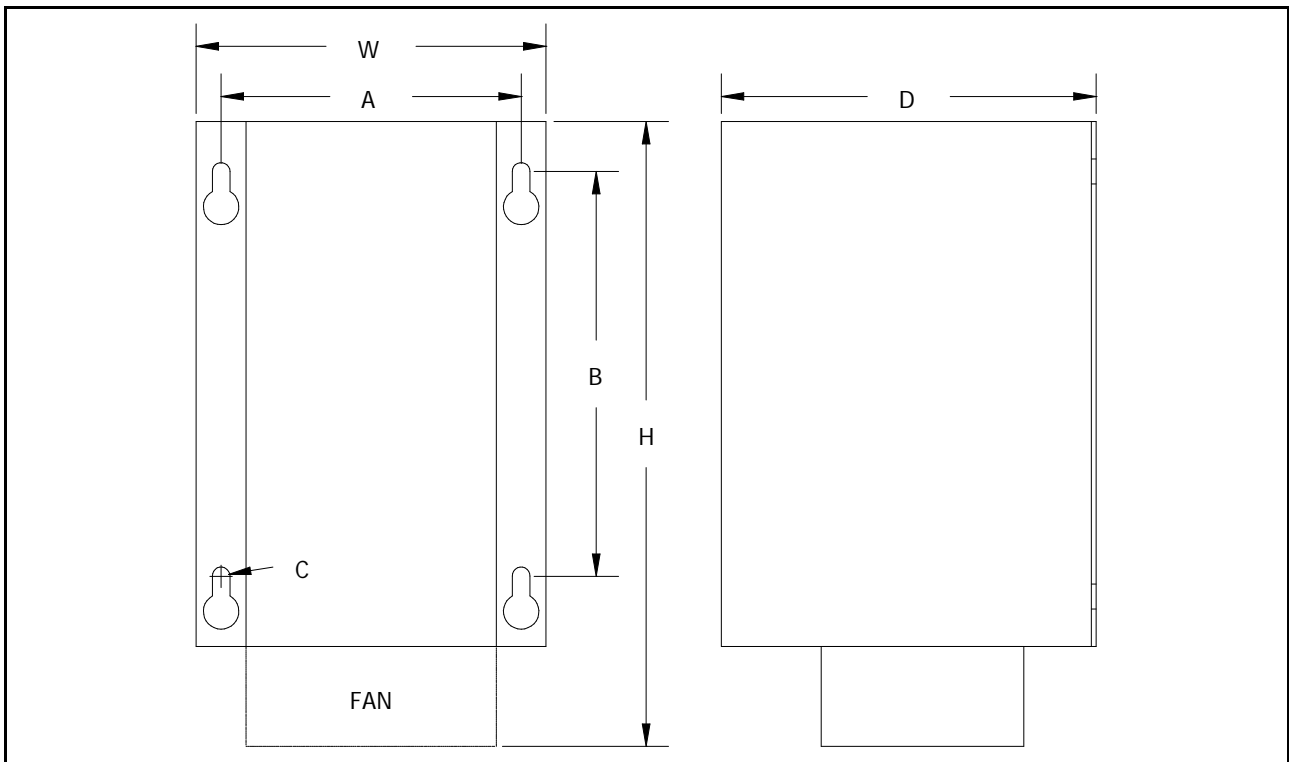

Figure 4. Dimensions.

DIMENSIONS

Current rating	Width 'W'	Height 'H'	Depth 'D'	Fixing centre 'A'	Fixing centre 'B'	Fixing holes 'C'
(For configurations in figure 1)						
40-55A	280	165	250	260	80	6
75-155A	380	160	280	260	110	6
(For configurations in figure 2)						
40-55A	280	165	250	260	80	6
75-155A	400	160	280	380	110	6

All dimensions are in mm.

SUPPLIER INFORMATION

Tactical Controls Limited
 Unit 1 Parkland Business Centre
 Chartwell Road, Lancing
 West Sussex BN15 8UE England
 Tel: (01903) 750800
 Fax: (01903) 750678
 Email: Email@TacticalControls.co.uk