

Tactical

TC310 LOW COST THREE TERM VERSATILE TEMPERATURE CONTROLLER

INSTRUCTION MANUAL

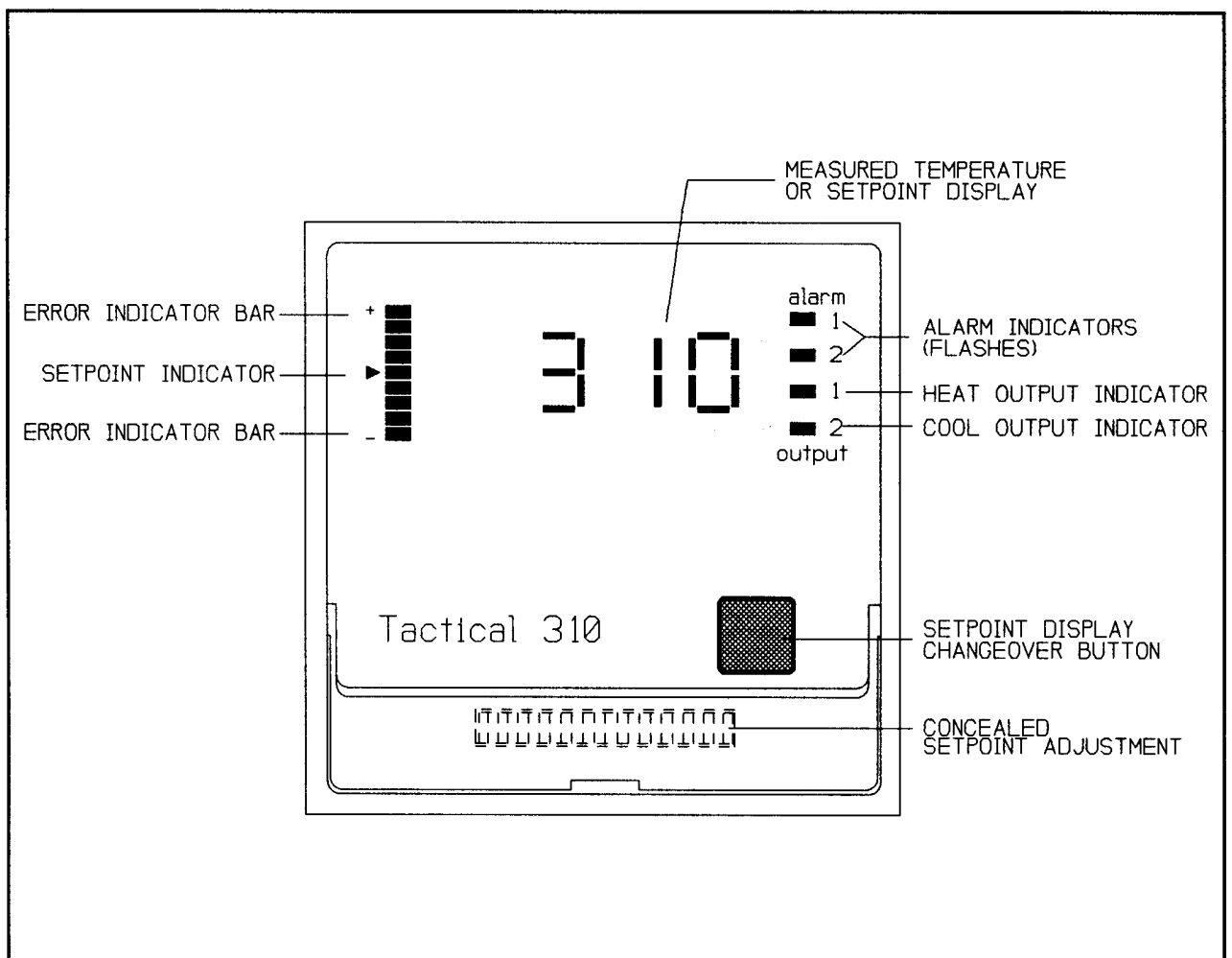

CONTENTS

DESCRIPTION	2	ALARM SETTING	6
INSTALLATION	2	TECHNICAL SPECIFICATION	7
CONNECTION	3	ORDERING INFORMATION	8
CONTROL ADJUSTMENTS	4	SUPPLIER INFORMATION	8
TUNING	5		

DESCRIPTION

The TC310 is housed in a durable sheet metal and flame retardent plastic housing with display panel at the front and wiring connections at the back. The seven segment LED display monitors measured value continuously and the nine segment error bar shows the proximity to

setpoint. Setpoint can be displayed by depressing the setpoint changeover switch on the front panel. Setpoint adjustment is made by turning the setpoint thumbwheel which is concealed behind the door on the front panel. Wiring connections are made at the back by means of screw type connectors. All control adjustments are on the top of the instrument.

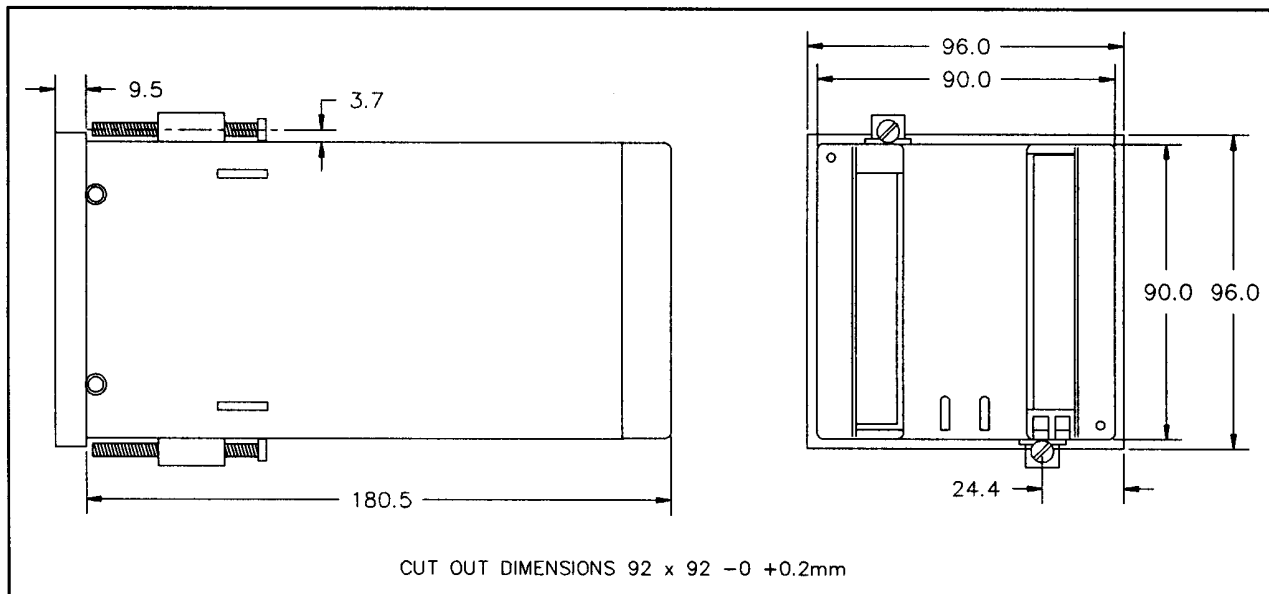

Dimensions.

INSTALLATION

The instrument requires a 92X92mm panel cut out and is fixed by retainers positioned on the top and bottom of the instrument. Maximum panel thickness is 10mm.

All external wiring is made to the rear of the instrument via M3 screw terminals.

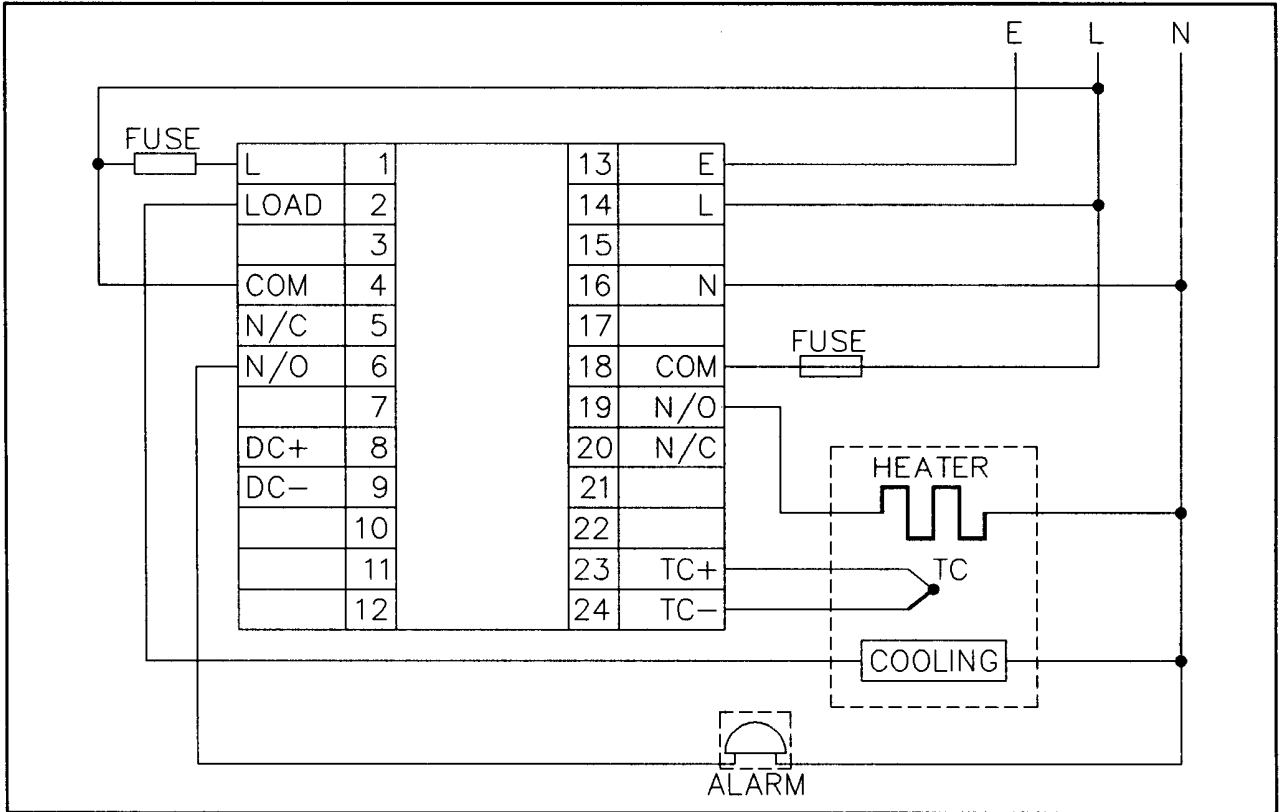

Typical TC310 wiring schematic.

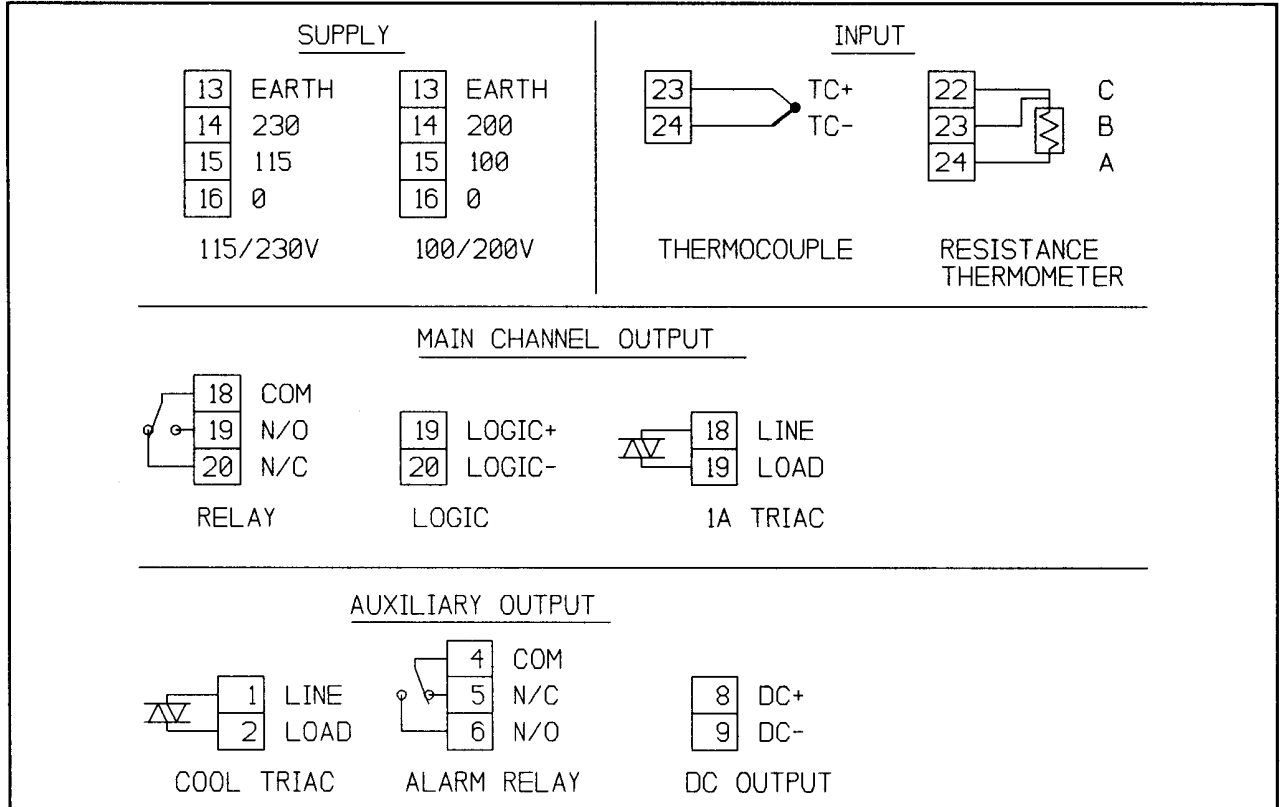

Terminal connection diagram.

CONTROL ADJUSTMENTS

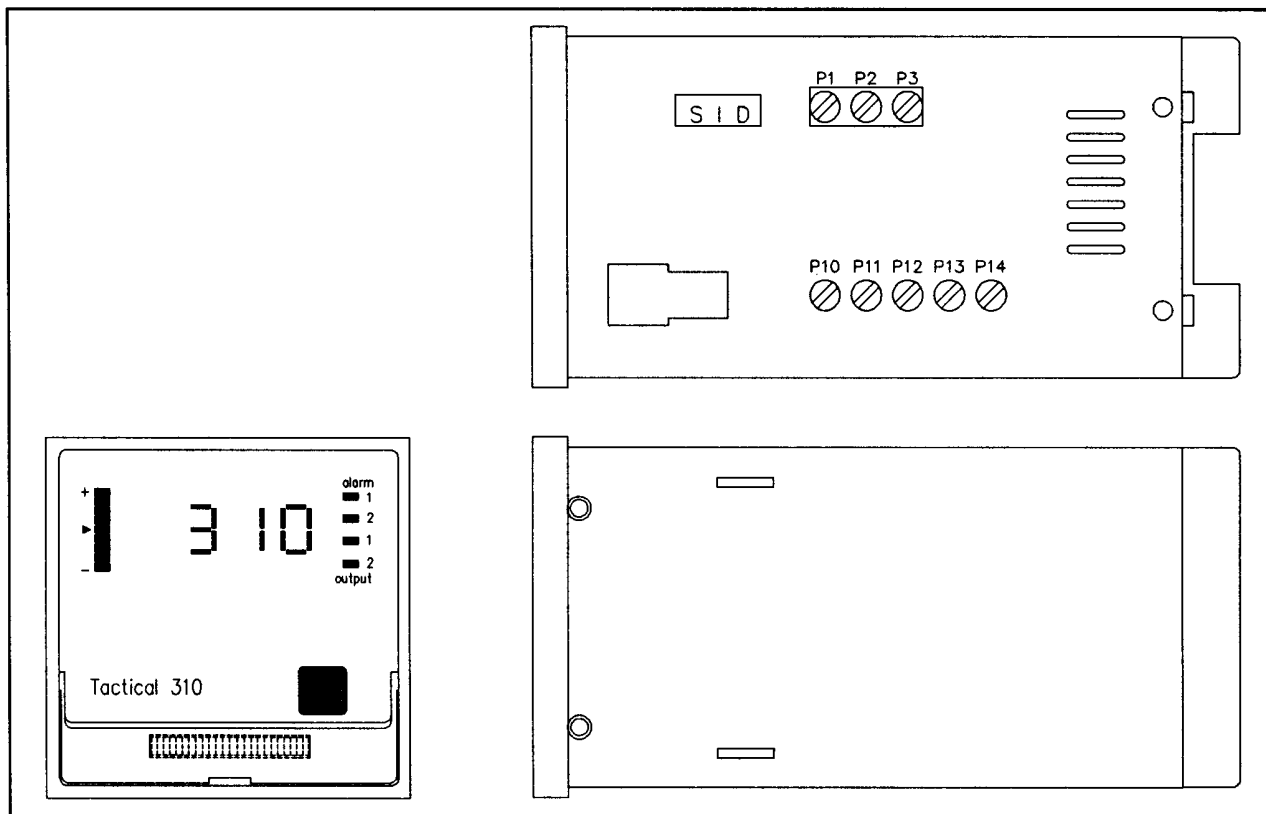

Control adjustments.

SID - Switching Integral & Derivative; the use of switches to change integral and derivative time constant simplifies the procedures in obtaining optimum control.

P1 - Proportional Band of 2.5-15% can be adjusted through this control.

P2 - Main Channel Cycle Time can be used to adjust the time proportional output cycle time of the main channel.

P3 - Manual Reset (optional) can be used to remove the steady state error inherent in PD control.

P10 - High Setpoint Stops (optional) can be adjusted to provide an additional safeguard on the setpoint adjustment.

P11 - Low Setpoint Stops (optional) can be adjusted to provide an additional safeguard on the setpoint adjustment.

P12 - High/Low/Band Alarm (optional - only one type on any instrument) can be used to give a warning when the measured temperature exceeds the alarm limit.

P13 - Relative Cool Gain (optional) can be used to match the heating and cooling characteristics of a system.

P14 - Aux. Channel Cool Cycle Time (optional) can be used to adjust the time proportional output cycle time of the aux. cool channel.

TUNING

PID CONTROL TUNING PROCEDURE

1. Set main channel cycle time to maximum (P2 fully clockwise).
2. Set proportional band to minimum (P1 fully anticlockwise).
3. Set all SID switches to 'ON' (11111111).
4. Adjust the setpoint to 10% below working temperature.

N.B. If it is undesirable for the system to overshoot the working temperature, perform the test at a further reduced temperature.

5. Observe:-
 - a. Time (to) taken for the measured temperature to rise from the setpoint to a maximum.
 - b. Overshoot temperature (To) = maximum temperature - setpoint temperature.
6. Set the SID switches (see Table 1) to give $t_i = 4 \times t_o$. This will automatically set $t_d = t_i/9$.
7. From the overshoot temperature, To, calculate the proportional band index PBI as follows:-

$$PBI = (T_o / TR) \times 100$$

TR = 200 for -50 to 200 range
 TR = 500 for -50 to 500 range
 TR = 1000 for 0 to 999 range

and set the proportional band according to table 2.

8. Set P2 to minimum and when the system is controlling steadily at the selected set-temperature, in stages, increase the cycle time (by turning P2 clockwise), but if the longer ON and OFF times begin to induce cyclic variations of the measured temperature then shorten the cycle time (P2 anti-clockwise) just until the measured temperature is steady again.

Table 1. Switch settings for integral and derivative time constant.

SID	t _i (minute)	t _d (minute)	SID	t _i (minute)	t _d (minute)
12345678	50	5.5	12345678	23	2.6
00000000	46	5.2	10001000	20	2.2
00010001	43	4.8	10011001	17	1.9
00100010	40	4.4	10101010	13	1.5
00110011	36.5	4.1	10111011	10	1.1
01000100	33	3.7	11001100	7	0.8
01010101	30	.3	11011101	3	0.4
01100110	27	3.0	11101110		
01110111			11111111	ON/OFF CONTROL	

(For SID switch, 0 - off, 1 - on).

For fast time constant (option code 70), divide the standard t_i and t_d in table 1 by 10.
 For moderately fast time constant (option code 79), divide the standard t_i and t_d in table 1 by 20.
 For very fast time constant (option code 77), divide the standard t_i and t_d in table 1 by 100.
 For ultra fast time constant (option code 78), divide the standard t_i and t_d in table 1 by 1000.

Table 2. Proportional band index.

P1 MARKING	PBI	P1 MARKING	PBI	P1 MARKING	PBI
0	1	4	8.9 - 11.5	8	19.6 - 22.3
1	1 - 3.5	5	11.5 - 14.2	9	22.3 - 25.0
2	3.5 - 6.2	6	14.2 - 17.0	10	25
3	6.2 - 8.9	7	17.0 - 19.6		

PD CONTROL (OPTIONAL) TUNING PROCEDURE

1. Turn the manual reset to minimum (P3 fully anticlockwise).
2. Proceed as for PID control tuning procedure, use table 1 to set SID to give $td = 0.5 \times to$.
3. Turn P3 anticlockwise to eliminate any steady state error.
4. Set P2 as for PID control tuning procedure (8).

ON-OFF CONTROL (OPTIONAL) TUNING PROCEDURE

No adjustment is required for ON-OFF control.

AUX. COOL CHANNEL (OPTIONAL) TUNING PROCEDURE

For systems with an aux. cool channel, disconnect the aux. cool output and tune the main (heat) channel as above. Turn aux. channel cool cycle time to maximum (P14 fully clockwise) and relative cool gain to 1 (P13 centre position). Reconnect the aux. cool channel. Reduce either aux. channel cool cycle or relative cool gain (turn P14 or P13 anticlockwise) or both to reduce any oscillation. Increase the relative cool gain (turn P13 clockwise) for greater cooling effect.

ALARM SETTING

PROCEDURE FOR SETTING ALARM ON TC310

For alarm setting purposes, the controller may be in either the control or the open loop mode, provided that the input signal from the sensor to the controller remains steady at any convenient level during the short period of time that it takes to set the alarm level.

1. STEPS IN SETTING UP A HIGH ALARM LEVEL

- 1.1 Ensure that the sensor input to the controller is at a steady temperature T1.
- 1.2 Turn the alarm setting control P12 fully clockwise.
- 1.3 Decide how many degrees above the set temperature the alarm must operate. Let this be t degrees.
- 1.4 By means of the thumbwheel, adjust the set temperature of the controller to be t degrees lower than the sensor input temperature T1.
- 1.5 Adjust the alarm setting control P12 anti-clockwise until the alarm relay LED just comes on. The high alarm will now operate at t degrees above any chosen set point temperature.

2. STEPS IN SETTING A LOW ALARM LEVEL

- 2.1 Ensure that the sensor input to the controller is at a steady temperature T1.
- 2.2 Turn the alarm setting control P12 fully clockwise.
- 2.3 Decide how many degrees below the set temperature the alarm must operate. Let this be t degrees.
- 2.4 By means of the thumbwheel, adjust the set temperature of the controller to be t degrees higher than the sensor input temperature T1.
- 2.5 Adjust the alarm setting control P12 anti-clockwise until the alarm relay LED just comes on. The low alarm will now operate at t degrees below any chosen set point temperature.

3. STEPS IN SETTING UP A BAND ALARM

The band alarm operates when the actual temperature is t degrees higher than the set temperature or t degrees lower than the set temperature. Therefore the band alarm may be set by setting up the high end in the same manner as section one above or by setting the low end in the same manner as section two above.

TECHNICAL SPECIFICATION

INPUT

Thermocouple Standard
Cold junction compensation
Thermocouple break protection

Resistance Thermometer 2 or 3 wire

RTD (Pt 100)

OUTPUTS

HEAT OUTPUT

Relay
Logic output (option)
Triac output (option)
Power feedback

COOL OUTPUT (option)

Triac
Linear Cool

Non-linear Cool

Relative proportional band

ALARMS OUTPUTS (option)

Relay

Alarm LED

Low deviation
High deviation
Band deviation

CONTROL

PID control

Proportional band X_p
Integral time t_i
Derivative time t_d

PD control (option)

Proportional band X_p
Derivative time t_d
Manual reset

ON/OFF control (option)

ENVIRONMENTAL

Supply voltage

Operating temperature

Storage temperature

PERFORMANCE

Indication accuracy
Supply voltage variation

GENERAL

Display digit

Error indication

Dimensions

Weight

Power consumption

ASTM E230, BS4937, DIN 43710.

Automatic.

Upscale fitted as standard, display shows "bbb." (b:blank)

Downscale fitted as an option.

Any lead resistance error is automatically reduced by using 3 wires.

BS 1904, DIN 43760.

Cycle time adjustable 4 to 20 seconds at 50% power.

5A resistive at 230V rms.

Non-isolated 10mA 12V dc.

1A or 13A at 230 Vrms.

To stabilise output against line voltage variation.

1A at 230Vrms.

For fan cooling applications; cycle time adjustable from 4 to 20 seconds at 50% power.

For water cooling applications; cycle time adjustable from 0.5 to 10 seconds at 50% power; minimum on pulse 60 milliseconds.

0.25 to 3.00 times of heat proportional band.

Normally energised and de-energised in alarm conditions. 2A resistive at 230Vrms.

Flashing LED at fascia.

Adjustable +0.5% to -8% of span.

Adjustable -0.5% to +8% of span.

Adjustable 1.5% to 8% of span.

Proportional, Integral and Derivative.

2.5% to 15% of span.

Switching integral time 5 to 40 minutes.

Switching derivative time 0.5 to 5 minutes.

Proportional and derivative.

2.5% to 15% of span.

0.5 to 5 minutes.

PD control only, 0 to 50% output power at span.

Hysteretic 0.5% of span.

115/230V +/-15% 50/60Hz

100/200V +10% -15% 50/60Hz.

0 to 50 °C.

-20 to +80 °C.

Better than 0.5% of span +/-1 digit.

Negligible effect within operating range.

3 digit 7 segment with negative sign display; digit size 13mm height by 7.4mm width.

9 LED display bar; central LED +/- 0.4% of span

+/-1 degree and +/-0.8% of span +/-1 degree

per LED above and below setpoint.

96x96x190mm.

2Kg maximum.

6VA maximum.

ORDERING INFORMATION

You are welcome to order by description or code.

310- - - - -00

INPUT: : : : :
 SCALE: : : : :
 OUTPUT: : : : :
 SUPPLY VOLTAGE: : : : :
 OPTION: : : : :
 END OF CODE: : : : :

INPUT

- Iron-Constantan (J) -50 to 500 1
- Chromel Alumel (K) -50 to 500 2
- Chromel Alumel (K) 0 to 999 3
- Resistance Thermometer (PT100) -50 to 200 4
- (Other range options on application)

SCALE

- Degree CelsiusC
- Degree FahrenheitF

OUTPUT

- Heat relay 1
- Heat logic 2
- Heat triac 1A 3

SUPPLY VOLTAGE

- 115/230V +/-15% 50/60Hz 1
- 100/200V +10% -15% 50/60Hz 2

OPTIONS

- No option01
- Cool output linear11
- Cool output non-linear12
- Low deviation alarm21
- High deviation alarm22
- Band deviation alarm23
- Two term PD Control31
- On-off control32
- Non-isolated DC output (heat control) 0-10mA (1000 ohms max.) ... 41
- Non-isolated DC output (heat control) 4-20mA (500 ohms max.) 42
- Non-isolated DC output (heat control) 0-20mA (500 ohms max) 43
- Non-isolated DC output (heat control) 0-5V (8mA max.)44
- Non-isolated DC output (heat control) 0-10V (8mA max.)45
- Hign and low setpoint stops51
- Downscale Thermocouple break protection61
- Fast time constant 1/10 of ti & td70
- Very fast time constant 1/100 of ti & td77
- Ultra fast time constant 1/1000 of ti & td78
- Moderately fast time constant 1/20 of ti & td79

END OF CODE 00

ORDER EXAMPLES:

1. A TC310 with J-type thermocouple input, scaled -50 to 500 °C, relay heat output, operating at 230V and without any option will have the code:- 310-1-C-1-1-01-00.
2. A TC310 with K-type thermocouple input, scaled 0 to 999 °C, triac heat output, operating at 200V, with linear cool output, high deviation alarm, proportional plus derivative (PD) control and Downscale Thermocouple break protection as options will have the code:- 310-3-C-3-2-11-22-31-61-00.

SUPPLIER INFORMATION

Tactical Controls Limited
 Unit 4, Marlborough Road
 Lancing, West Sussex BN15 8TR
 England
 Tel: (01903) 750800
 Fax: (01903) 750678