

Tactical



TC170 Thyristor Failure Detection Unit Instruction Manual

Contents

Introduction	2
Block diagram	2
Description.....	3
Three phase system connection.....	3
Single phase system connection	6
Installation	6
Calibration.....	6
Technical Specification.....	7
Ordering information.....	8
Supplier information.....	8

Copyright (C) 1998 Tactical Controls Limited

This document contains proprietary information which is protected by copyright. All rights reserved. This document or parts thereof may not be reproduced in any form without written permission of the publishers.

The information in this document is subject to change without notice and should not be construed as a commitment by Tactical Controls Limited. Tactical Controls Limited shall not be liable for errors contained herein or for incidental or consequential damages in connection with the furnishing, performance or use of this material.

Introduction

Using state of the art single-chip microcontroller technology, the TC170 is designed to detect high electrical power thyristors open-circuit, short-circuit, or partial load failure faults.

It is designed for single phase or three phase AC to AC thyristor power controls, suitable for thyristors operating in single-cycle, fast-cycle and slow cycle time-proportioning mode. These are normally used in heating applications.

Thyristors normally become short-circuit between anode and cathode, due to excessive heating or persistent overload current. Another cause of thyristors short-circuit is excessive anode-cathode voltage.

Rarely thyristors become open-circuit, more often, these are due to fuse failure, open-circuited or partial load failure, or defective gate drives to the thyristors. For this reason, when the TC170 gives an open-circuit alarm, other parts could be open-circuited, such as partial load failure.

The TC170 uses the thyristor logic control signals and current signals to determine whether the thyristor circuits is open, short-circuited or there is a partial load failure.

Block diagram

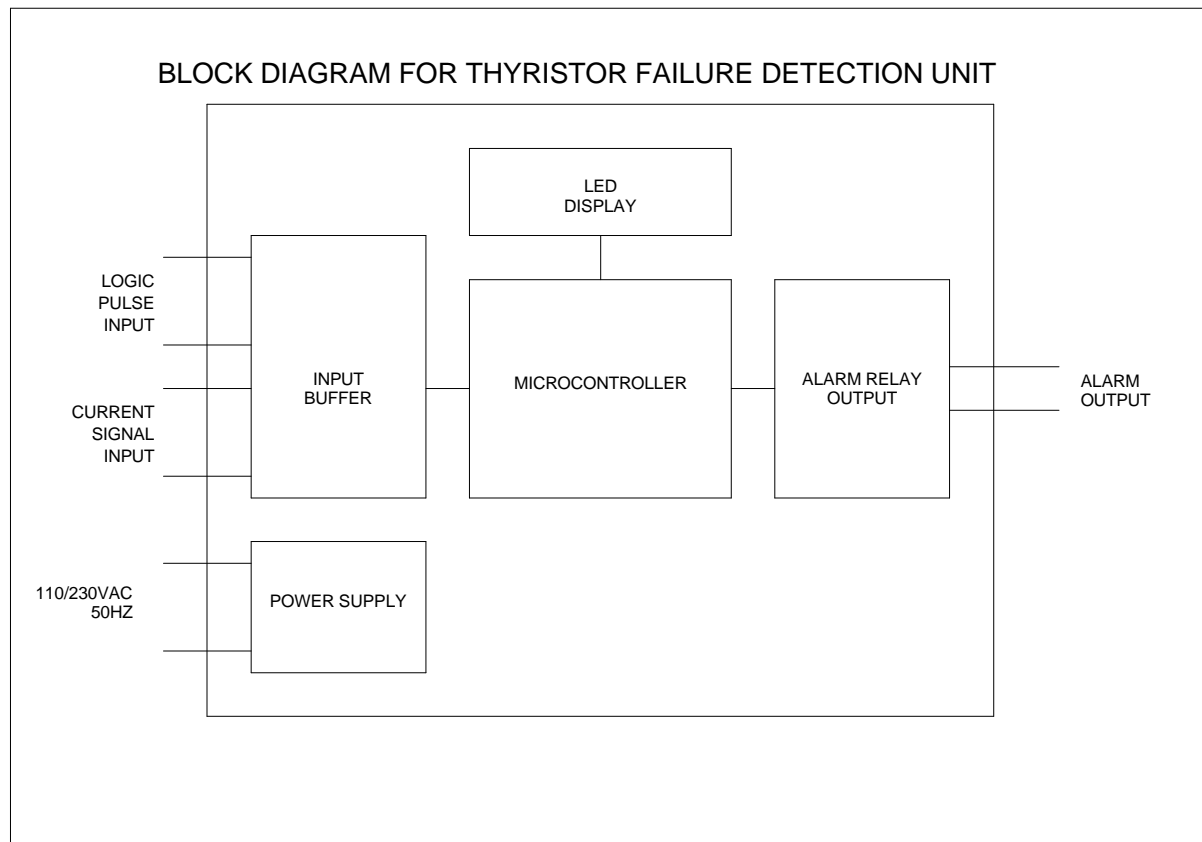

Description

The TC170 is housed in fully insulated enclosure with fully insulated input and output. The enclosure can be either backplate or DIN-rail mounted.

The TC170 can accept up to three logic signal pulse trains and three current signals for either 3 independent single phase application or one 3 phase application.

At the heart of the TC170 is a microcontroller which monitors the logic signal and its correspondent current signal to determine whether any thyristor and/or load fault exist.

Any fault will cause the alarm output relay to de-energise. This is accomplished by the fault LEDs (Red) which indicate which channel is at fault and whether it is an open-circuit or short-circuit. The Normal LED (Green) will go out whenever there is a fault.

Three phase system connection

Figures 1 through 4 show four common 3-phase load configurations:

1. Figure 1, 3-wire closed-delta.
2. Figure 2, 3-wire star.
3. Figure 3, 4-wire star.
4. Figure 4, 3-wire open-delta.

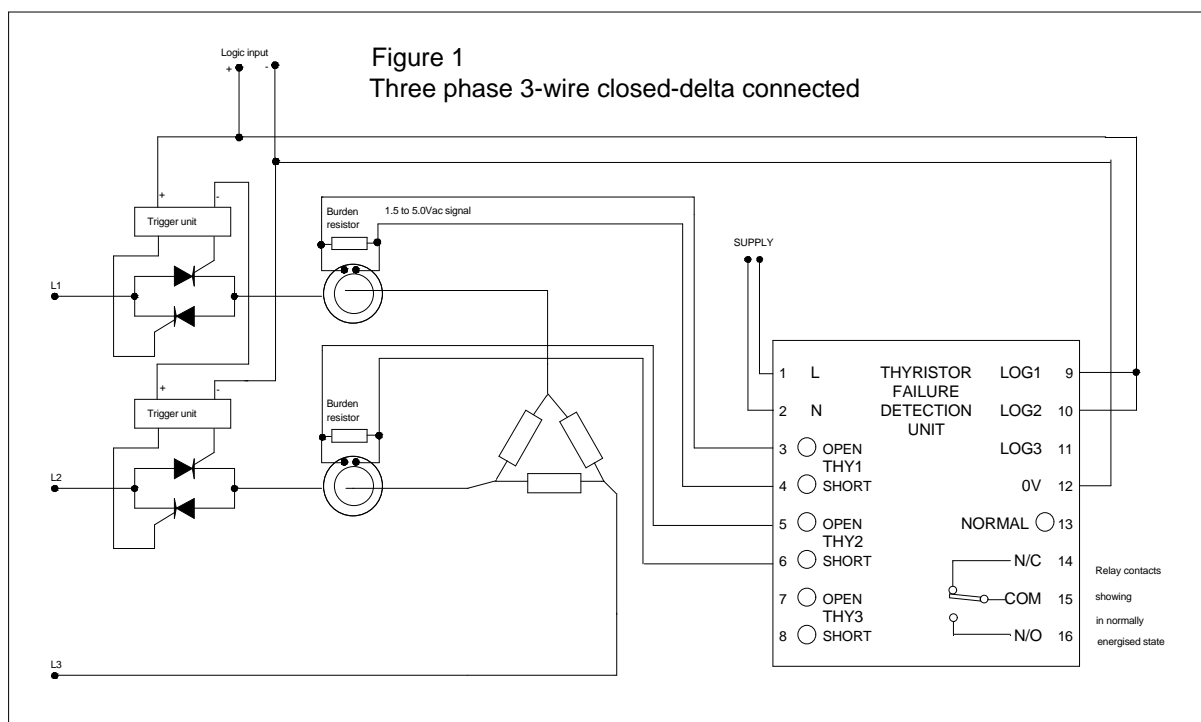

Thyristor configurations shown in figure 1 and 2 require only two thyristor assemblies connected to any two of the supply lines.

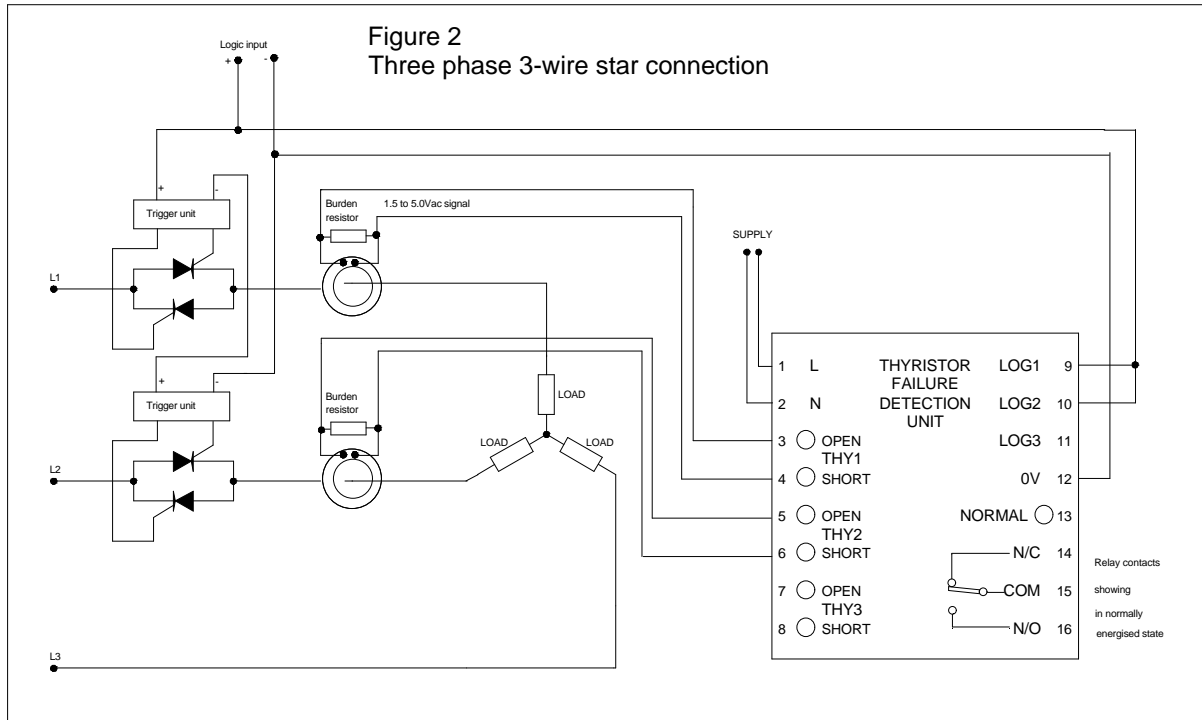

In 4-wire star connected load (figure 3), the neutral wire must be rated 1.4 times the maximum line current.

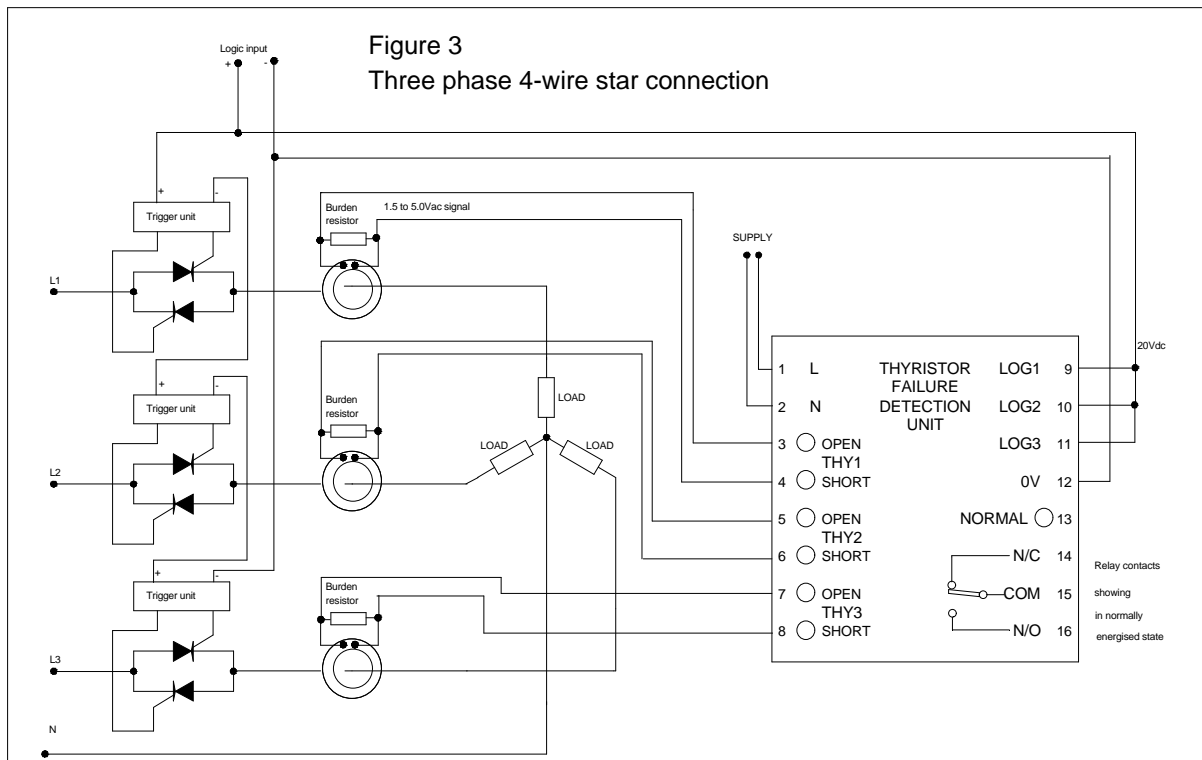

Note that if Figure 3 is used without the Neutral wire, then the TC170 is unable to detect if one thyristor becomes shorted. It would only give a short-circuit alarm if two thyristors from a different lines become shorted.

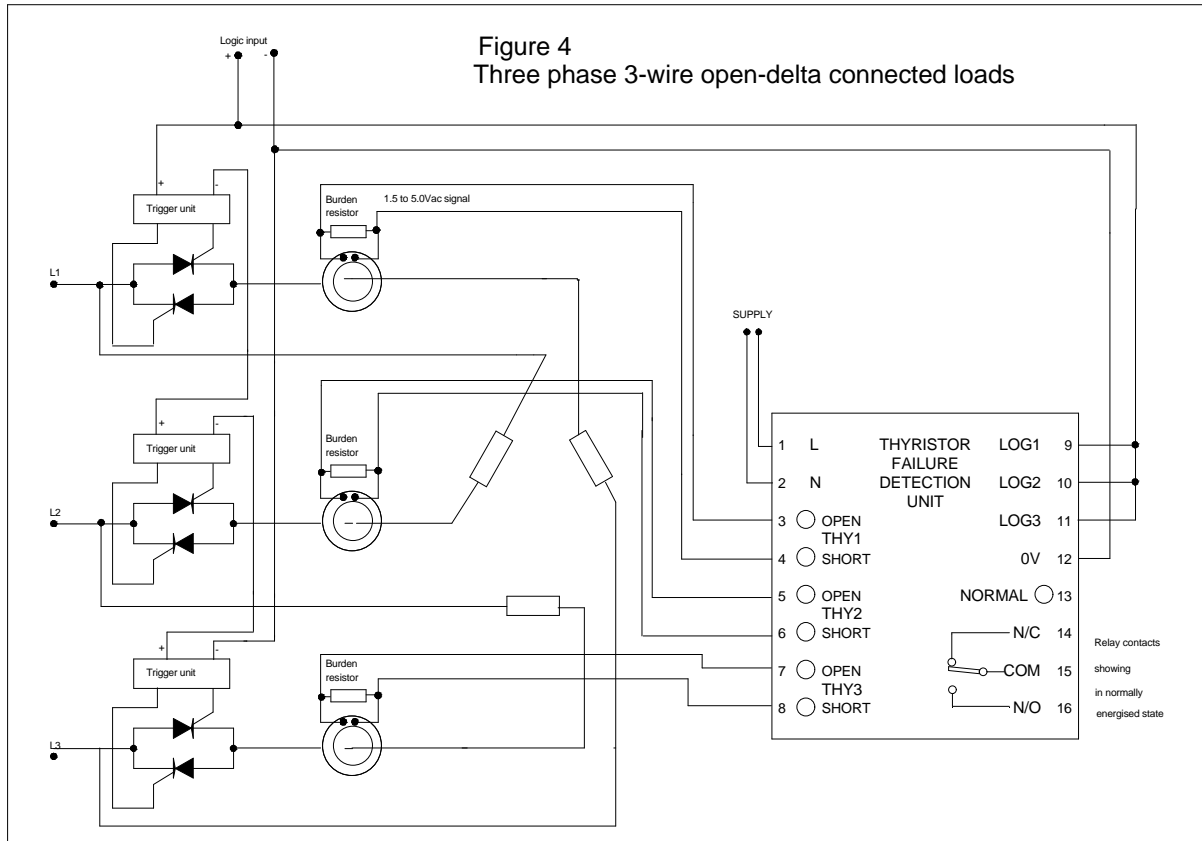

The TC170 supply must be derived from the three phase supply of the load; either L1, L2 or L3 and the neutral supply line. As these supply lines are being monitored by the TC170 to provide mains voltage compensation and to minimise false alarm.

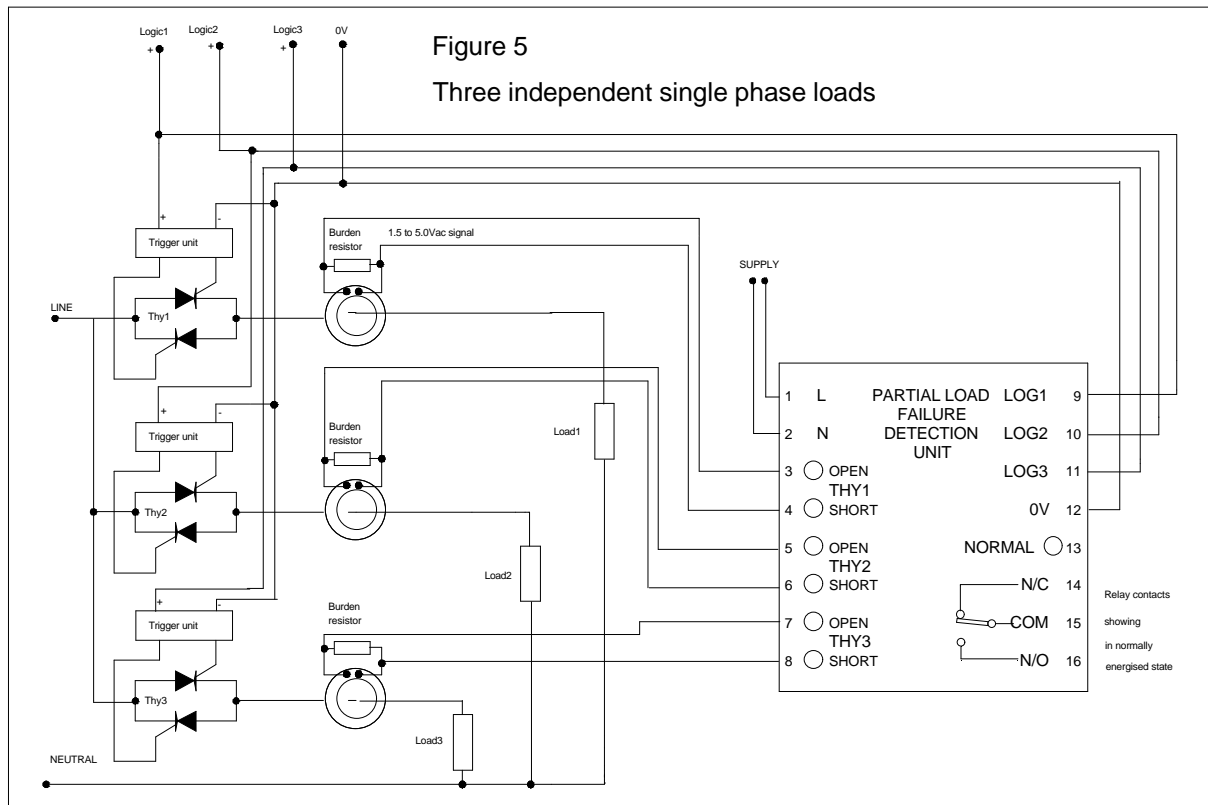

Single phase system connection

The TC170 is suitable for detecting up to three pairs of inverse-parallel connected thyristors operating in a single phase mode, as shown in figure 5.

Installation

The TC170 can be mounted either by means of screws passed through the two holes to DIN46121 and DIN43660 or by a snap fastener for fitting to DIN46277 and DIN EN50022 assembly rails.

All connections are made via screw terminals on the top of the unit.

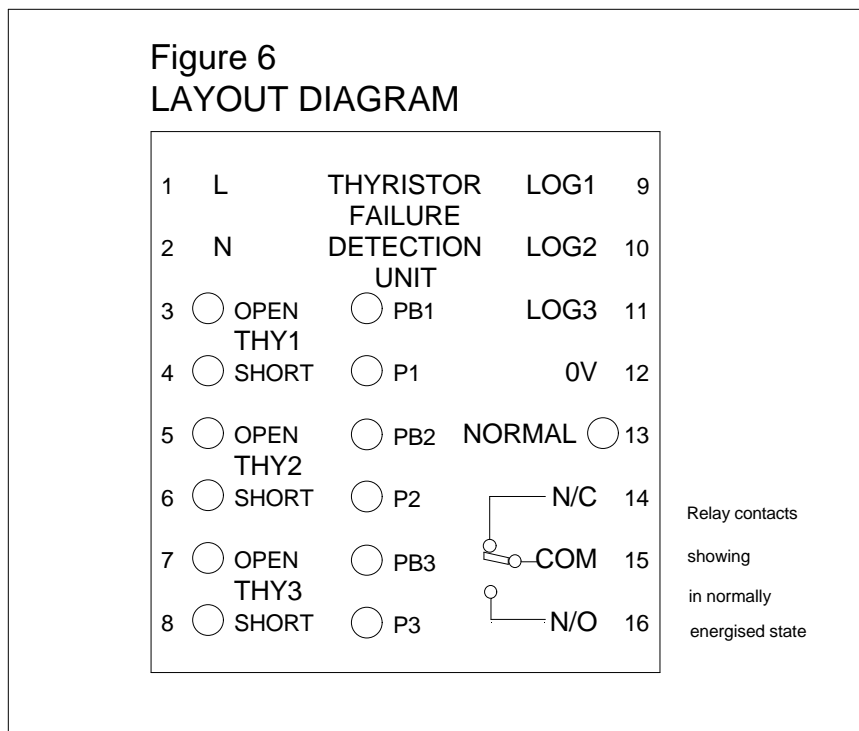

Calibration

The TC170 should be calibrated with full load and 100% power at nominal supply voltage.

The same calibration procedure applies to each of the three channels and each channel has to be calibrated separately. The following procedure is for channel 1.

1. Adjust the burden resistor of the current transformer of channel 1 to read 2.5Vac at full load and 100% power.
2. Measure the burden resistor and replace it with a fixed resistor if desired.

This completes the calibration procedure for channel 1.

Technical specification**SUPPLY**

Mains power 230/115Vac, 50/60Hz.

INPUTS

Logic input 5-30Vdc; 0.2mA maximum; derive from thyristor logic input.

Current signal input 1-5Vac; current transformers are to be externally mounted.

Input impedance 10K ohm.

Maximum voltage 50Vdc (without causing damage to the input)

INDICATIONS

Normal LED illuminates when power in ON and no fault is present.

Line 1 Alarms LED illuminates when line 1 thyristor short-circuited.
LED illuminates when line 1 thyristor/load open-circuited.

Line 2 Alarms LED illuminates when line 2 thyristor short-circuited.
LED illuminates when line 2 thyristor/load open-circuited.

Line 3 Alarms LED illuminates when line 3 thyristor short-circuited.
LED illuminates when line 3 thyristor/load open-circuited.

RELAY OUTPUTS

Alarm relay Relay normally energised; change-over contacts; 1A, 240Vac.

MECHANICAL

Housing 110x75x55mm (height, width and depth)

Mounting By means of screws passed through two holes to DIN 46121 and DIN 43660 or by snap fastener for fitting to DIN 46277 and DIN EN 50022 assembly rails.

ENVIRONMENT

Operating temperature -10 to 50°C.

Relative humidity 0 - 90%.

Ordering information

Ordering code: TC170

You are welcome to order the unit by code or by description - TC170 Thyristor failure detection unit.

Supplier information

Tactical Controls Limited

Unit 1 Parkland Business Centre

Chartwell Road, Lancing

West Sussex BN15 8UE England

Tel: (01903) 750800

Fax: (01903) 750678

Email: Email@TacticalControls.co.uk